

smonet

# SMART LOCK

User Manual

Model:H1-BF

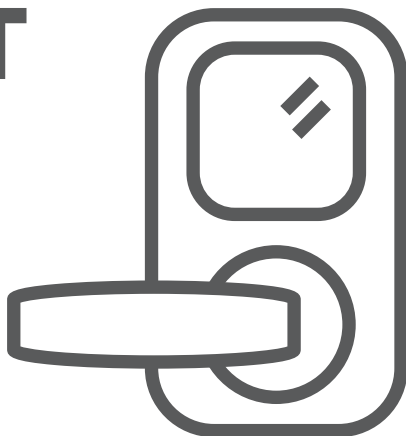

---

Read the user manual before use and keep it for further reference.

---



Scan me

Installation



APP Download



# Contents

<b>In the Box</b> .....	01
<b>Product Overview</b> .....	02
<b>Preparation</b> .....	03
Check Your Door Dimensions .....	03
<b>Installation</b> .....	04
Install the Latch .....	04
Install the Strike Plate .....	05
Change the Handle Direction .....	05
Install the Exterior Assembly .....	07
Install the Mounting Plate .....	08
Install the Interior Assembly .....	08
Insert the Batteries .....	09
<b>Test the Lock</b> .....	10
<b>Using the App</b> .....	11
Create an Account .....	11
Pair Your Phone with the Smart Lock .....	11
Change the Admin Passcode .....	13
APP Homepage Overview .....	14
<b>Basic Operations</b> .....	22
Unlock the Door .....	22
Lock the Door .....	22
How to Reset the Lock .....	23
<b>Smart Home Integration</b> .....	24
Enabling G2 Gateway .....	24
Enabling Amazon Alexa .....	26
Enabling Google Home .....	27
<b>Troubleshooting</b> .....	28
<b>Customer Service</b> .....	29

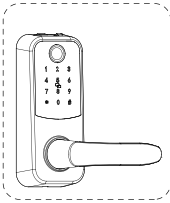

Exterior Assembly

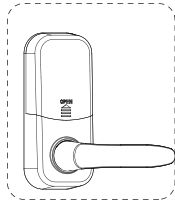

Interior Assembly

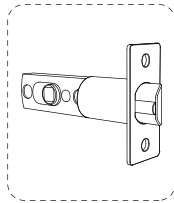

Latch

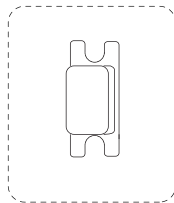

Strike Pad

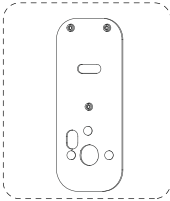

Mounting Plate

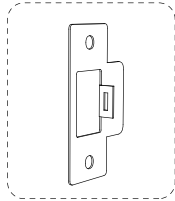

Strike Plate

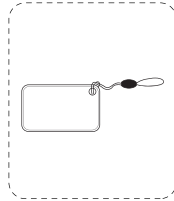

IC Card

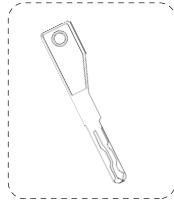

Key

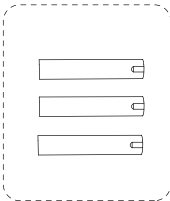

Screw Casing

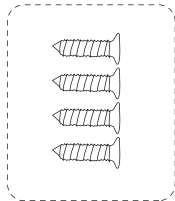

Strike & Latch Screws

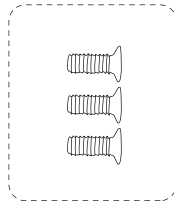

Back Panel Screws

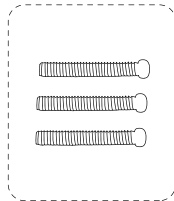

Mounting Plate Screws

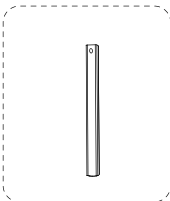

Spindle

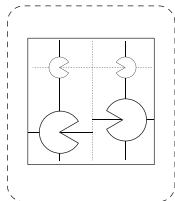

Drill Template



User Manual

# Product Overview

## Front

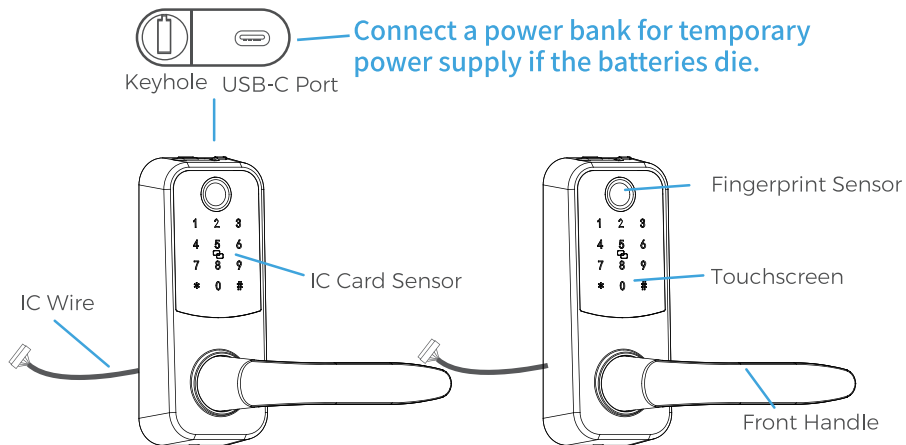

## Back

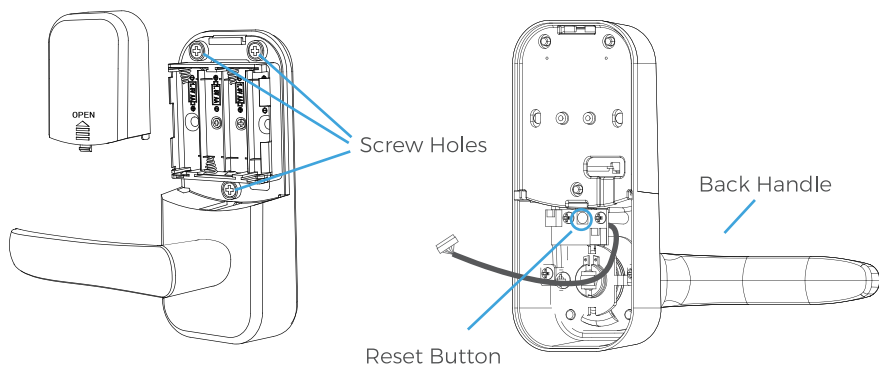

## Check Your Door Dimensions

Cross bore diameter:  
54 mm (2.13 inches)

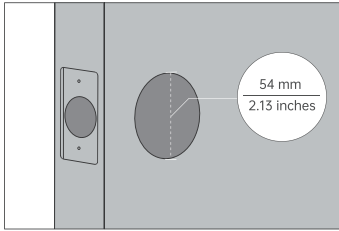

Backset:  
60 / 70 mm (2.36 / 2.76 inches)

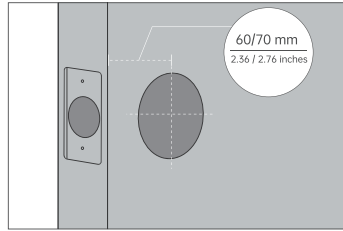

Door thickness:  
38 to 48 mm (1.5 / 1.89 inches )

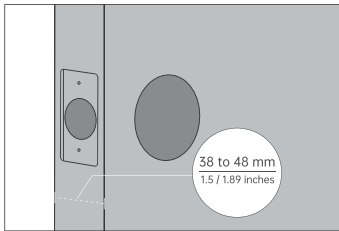

Edge bore diameter:  
24 mm (0.94 inch)

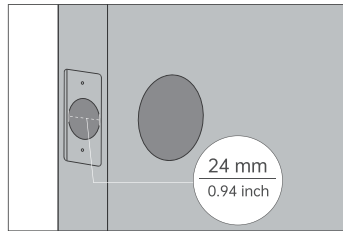

## Step 1: Install the Latch

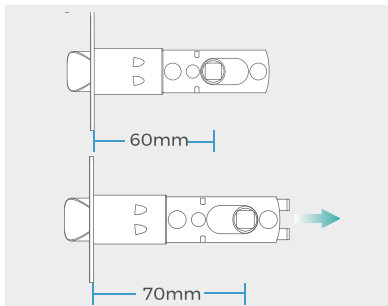

- If your door has a **60mm** / 2 3/8" backset, you can install the latch without any adjustments.
- For doors with a **70mm** / 2 3/4" backset, pull the latch to extend its length.

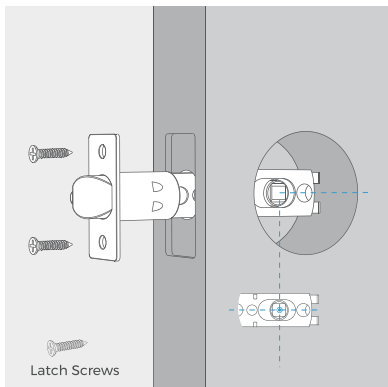

1. Insert the latch with its **tongue facing inside if your door opens outward**. Insert the latch with its **tongue facing outside if your door opens inward**.

2. Screw the latch with a Philips screwdriver (not provided).

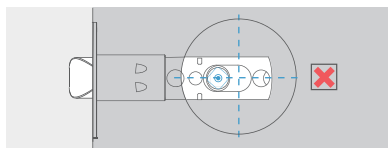

**Note:** Please ensure the center hole is square, not diamond-shaped.

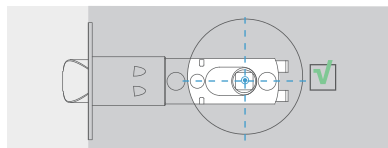

**Parts Required:** Latch, Latch Screws, Philips Screwdriver

## Step 2: Install the Strike Plate

1. Put the strike pad into the door frame first, and then screw the strike plate in place.

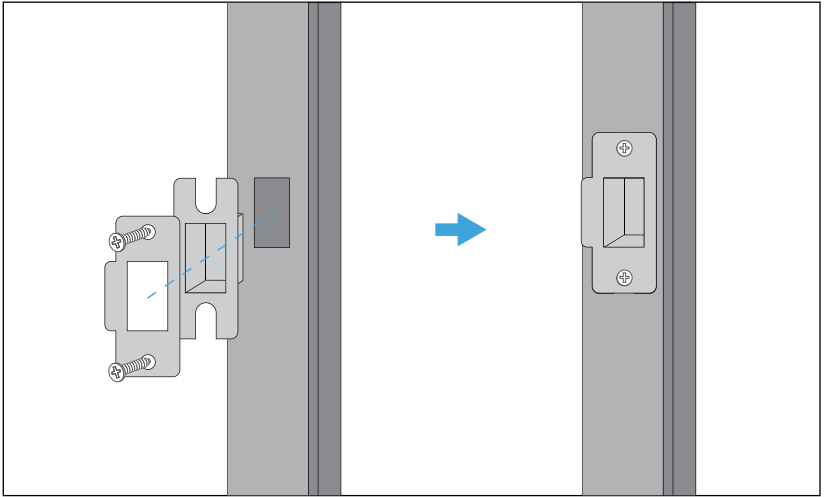

**Parts Required:** Strike Plate, Strike Pad, Strike Screws, Philips Screwdriver

## Step 3: Adjust the Handle Direction

1. Use a Phillips screwdriver to remove the screws in the front and back handles.

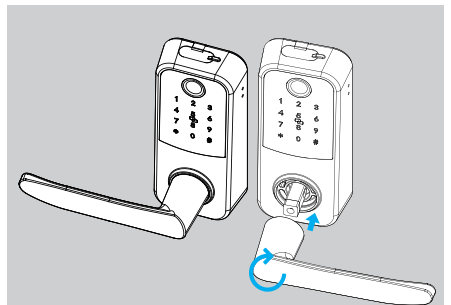
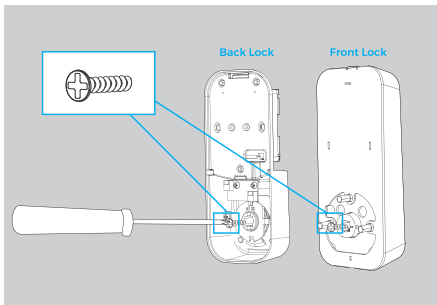



2.Face the door from the outside.

● **Left hand door**  
**(Hinge on the left)**

Turn the Front handle to Left  
Turn the Back handle to Right

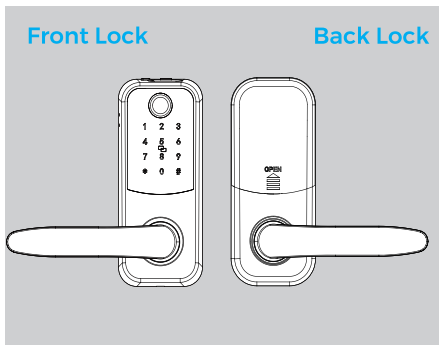

● **Right hand door**  
**(Hinge on the right)**

Turn the Front handle to Right  
Turn the Back handle to Left

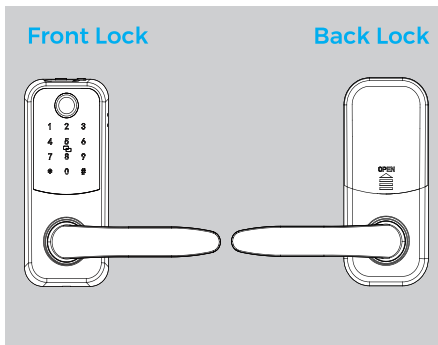

3. Tighten the screws to hold the handles in place.

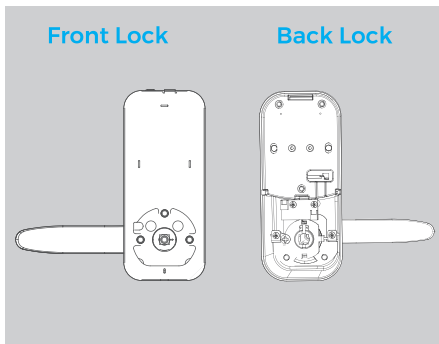

## Step 4: Install the Exterior Assembly

1. Insert the spindle while pressing the spring pin.

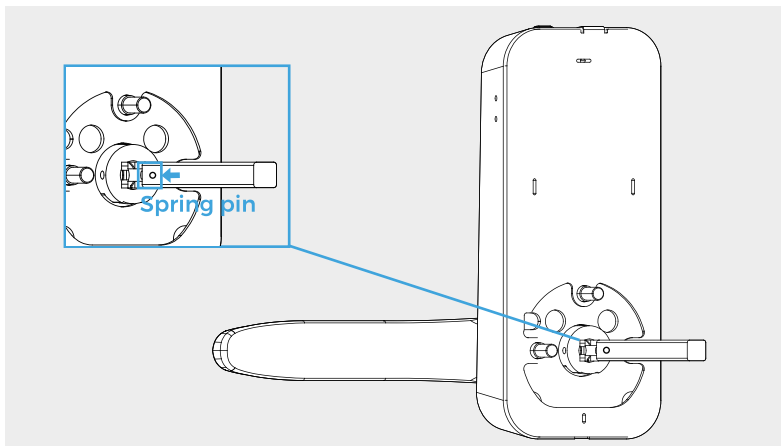

2. Install the screw casings by turning them clockwise.

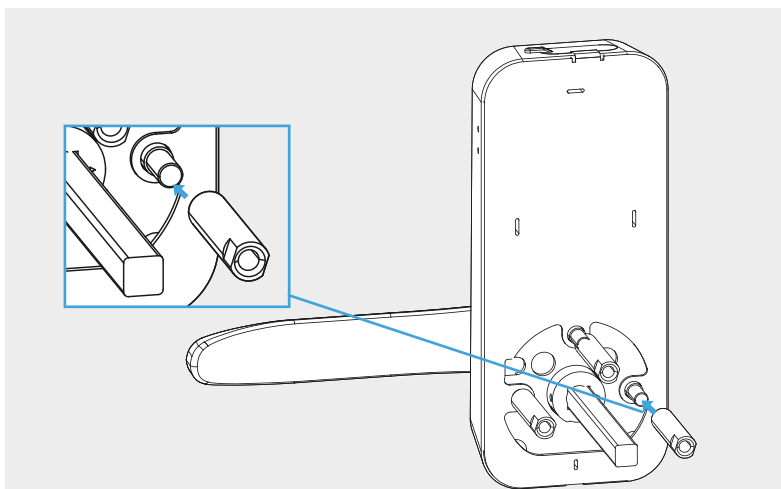

3. Install the exterior assembly while passing the cable under the latch.

**Part Required:** Gold Screw Casing, Spindle, Exterior Assembly

## Step 5: Install the Mounting Plate

1. Pass the spindle through the center hole and cable through the top left hole.

2. Screw the mounting plate firmly while ensuring proper alignment.

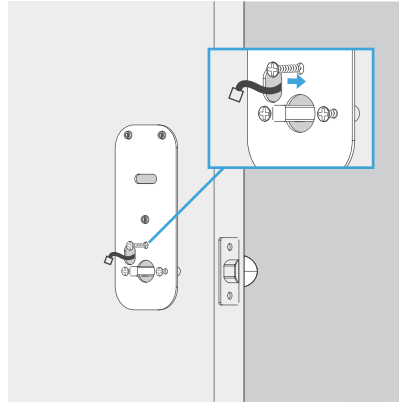
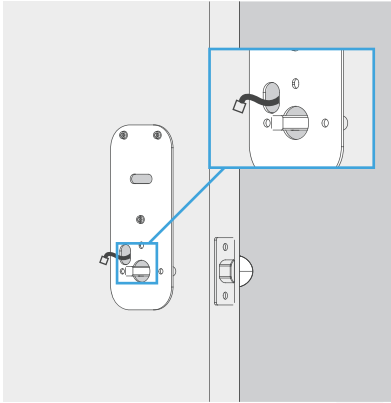

**Note:** Please keep the exterior assembly straight when installing the mounting plate.

**Parts Required:** Mounting Plate, Mounting Plate Screws, Philips Screwdriver

## Step 6: Install the Interior Assembly

1. Connect the cable and put the excess part into the top left hole.

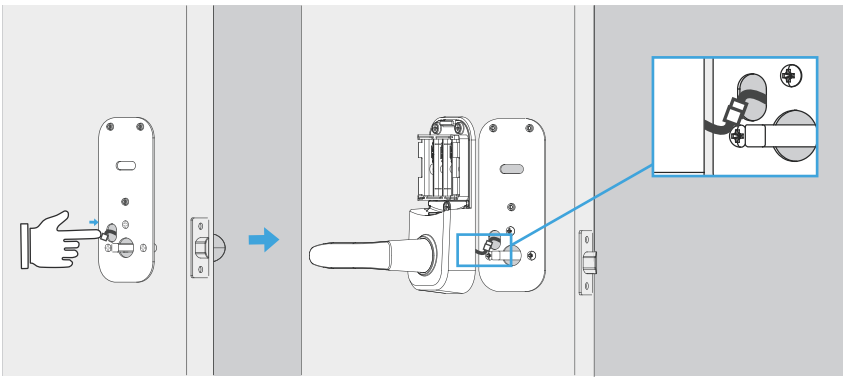

## 2. Screw the interior assembly.

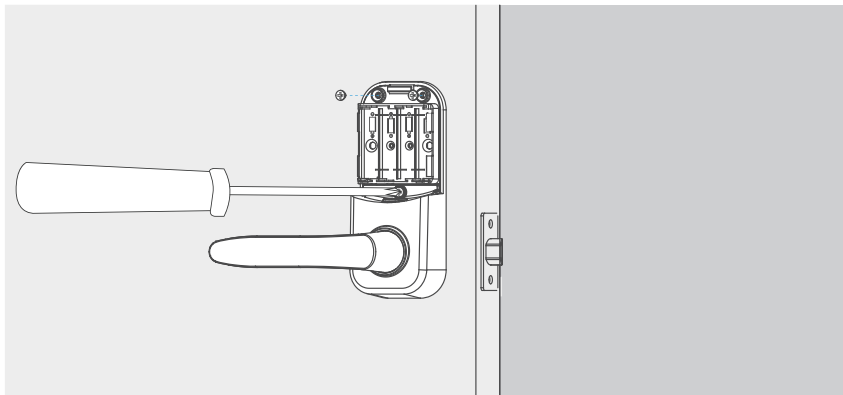

**Parts Required:** Interior Assembly, Interior Assembly Screws, Philips Screwdriver

## Step 7 Insert the Batteries

**Note:** Use new, non-rechargeable alkaline batteries only.

Slide the cover up.

4 AA alkaline batteries

Slide the cover back into place

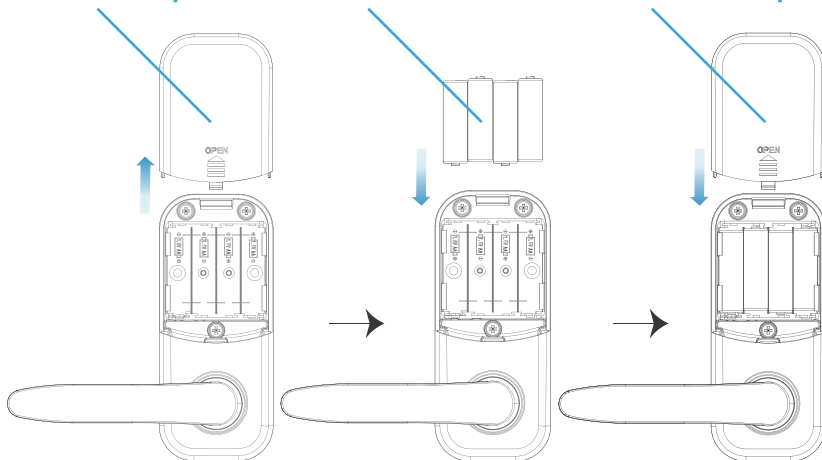

## Test the Lock

1. Keep the door open
2. Press the back handle to check whether the latch extends and retracts smoothly.
3. **Unlocking Test:** Enter the original admin passcode 123456# and then press the front handle.
4. **Locking:** The handle lock is automatically locked after 5 seconds.

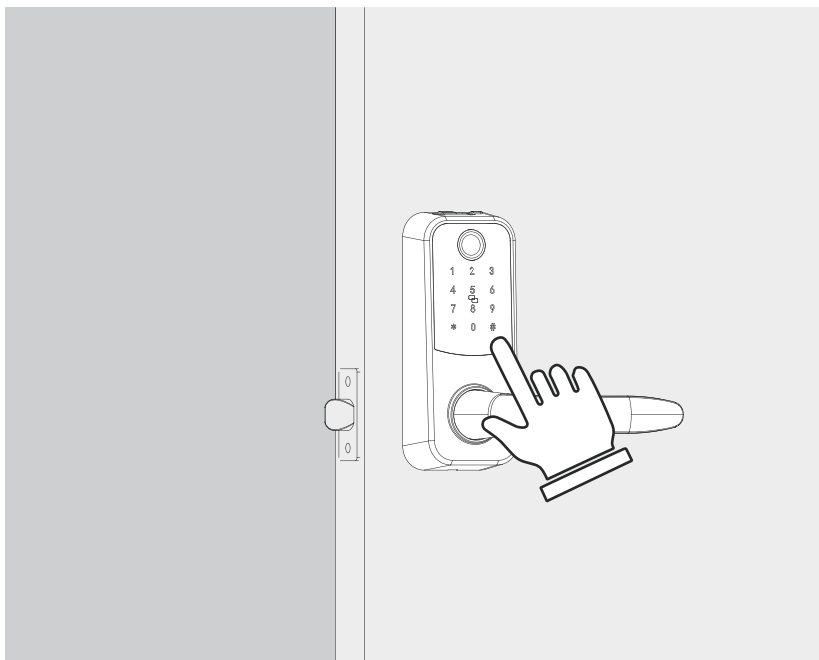

## 1. Create an Account

**Android:** Search “Next lock” or “TTLock” in Google Play.

**iOS:** Search “Next lock” or “TTLock” in the App store.

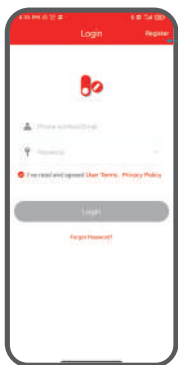

**STEP 1**  
Tap “Register”  
to continue

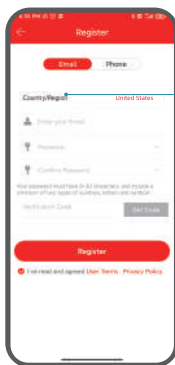

**STEP 2**  
Choose your Email  
or Phone number  
as your app account

## 2. Pair Your Phone with the Smart Lock



**STEP 1**  
Tap “menu”  
icon

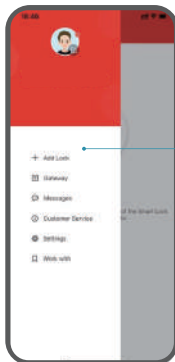

**STEP 2**  
Choose “Add lock”



**STEP 3**  
Tap "Next"

Touch any keys to activate the lock and put it in pairing mode.

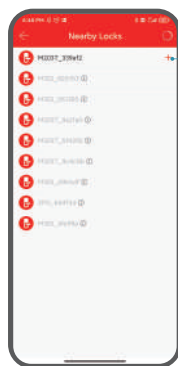

**STEP 4**  
Tap "+" to add lock(s)

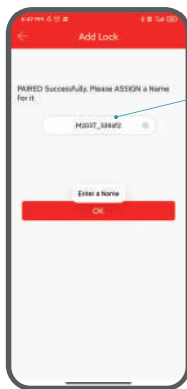

**STEP 5**  
Name your lock

### 3. Change the Admin Passcode

Once the lock and your phone are paired, the default administrator password 123456 is invalid.

- Check and set a new admin passcode:

Tap **Settings** on the home page → **Basics** → **Admin Passcode** →  
Enter a 4-9 digit password.

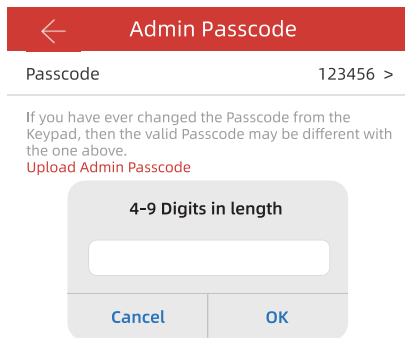
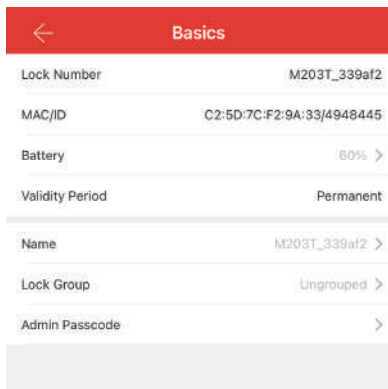



## 4.APP Homepage Overview

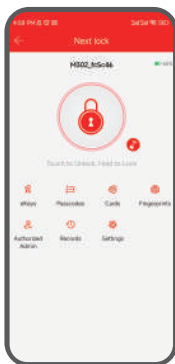

### Unlock/Lock

Unlock/Lock the door via Bluetooth



### eKeys

Manage and send eKeys to other users.



### Cards

Manage and add IC cards/fobs



### Records

Check the electronic locking and unlocking records



### Remote Unlock

G2 gateway required



### Passcodes

Manage and create keypad passcodes



### Fingerprints

Set and manage fingerprints



### Authorized Admin

Create and edit authorized admins for the lock



### Settings

Check and change settings

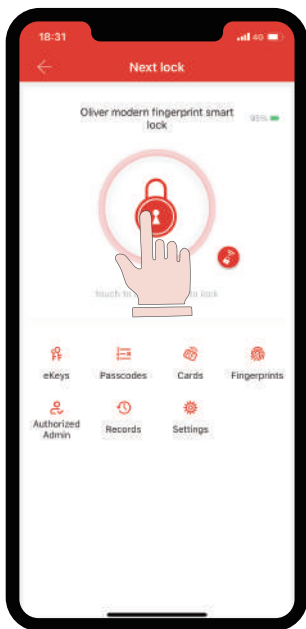

**Unlock:** Tap this big icon once  
**Lock:** Press and hold this big icon



### Remote control

**Unlock:** Tap the small lock icon. (Gateway Required)

**Lock:** Press and hold the big lock icon.

# EKeys

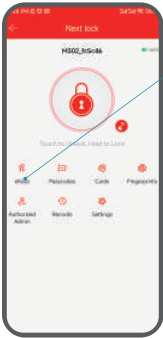

**STEP 1**  
Tap “eKeys”

Notes:

- 1.The recipient must create an account first with an email address or phone number.
2. Recipients are only allowed to use the app to unlock/lock the door and have no access to the settings of the lock.

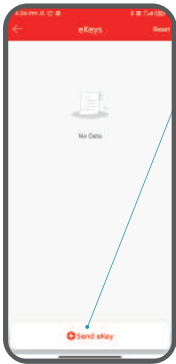

**STEP 2**  
Send eKey

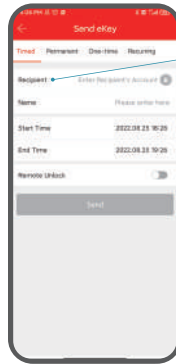

**STEP 3**  
Enter the recipient's account and name to send eKeys

# IC Cards

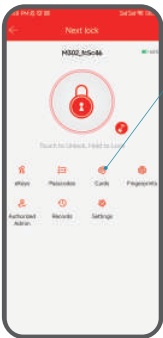

1. Tap “Cards”
2. Add card
3. Enter a name for the card
4. Place the card at the designated spot of the keypad when the lock says “Please swipe your card”
5. Input successful

# Passcodes

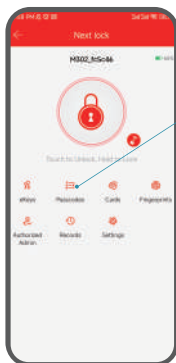

**STEP 1**  
Tap "Passcodes"

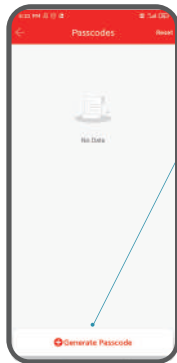

**STEP 2**  
Generate Passcode



**STEP 3**  
Choose the passcode type and name the passcode.

Note: To generate custom passcode, your phone must be within 5 meters of the lock if not paired with a gateway.

Except the custom passcode, all passcodes are generated randomly.

Permanent	Permanent passcode
Timed	Passcode with a time limit
One-time	Passcode that can only be used once
Custom	Customized passcode
Recurring	Passcode that are repeatedly valid on particular days of the week
Erase	Delete all other valid passcodes except the administrator passcode.

# Fingerprints

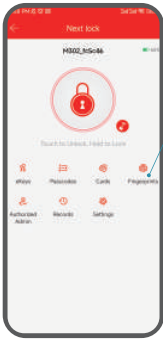

**STEP 1**  
Tap "Fingerprints"



**STEP 2**  
Add Fingerprint



**STEP 3**  
Name the fingerprint

**STEP 4**  
The lock will remind you to place your finger on the sensor 4 times

**STEP 5**  
Input successful

## For the lock to better recognize your fingerprints:

1. Make sure the fingerprint sensor and your finger are clean and dry.
2. Place your finger on the fingerprint sensor. Move your finger around to capture different parts of it.

# Authorized Admin



**STEP 1**  
Tap "Authorized Admin"

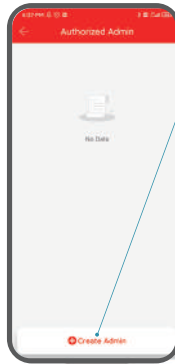

**STEP 2**  
Create Admin

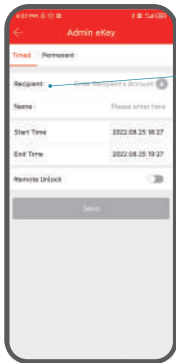

**STEP 3**  
Enter the recipient's account

Note:  
The authorized admin has all access rights except "Admin Passcode" and "Authorized Admins" .

# Auto Lock

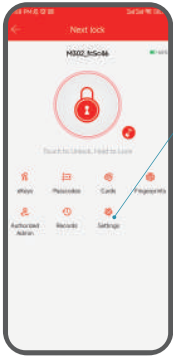

**STEP 1**  
Tap "Settings"

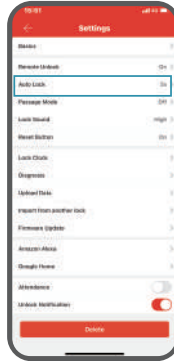

**STEP 2**  
SMONET handle lock is set to automatically lock after 5 seconds by default.



**STEP 3**  
Change or customize the interval (5-900 seconds).

# Passage Mode

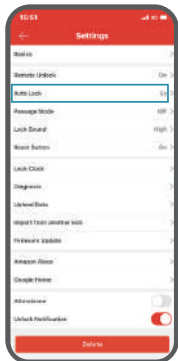

**STEP 1**

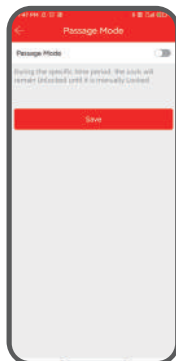

**STEP 2**  
Turn on  
“Passage Mode”

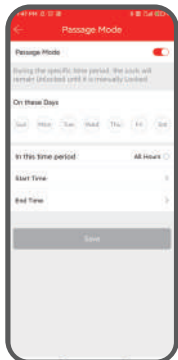

**STEP 3**

Choose the days and time this function works.

Notes:

1. When the “Passage Mode” function is enabled, the door remains unlocked and the “Auto Lock” function is disabled.
2. Unlock the door once to get the mode activated.



### **Unlock the Door**

Option 1: Touch any keys to light up the keypad first, then enter the passcode you have set and press the # key to unlock the door.

Option 2: Use the fingerprint sensor to unlock the door.

Option 3: Use the smart App on your phone or tablet, and tap the big lock icon to unlock the door.

Option 4: Use the keys provided to manually unlock the door.

Option 5: Swipe the IC card to unlock the door.

Option 6: Unlock your door with voice commands using Alexa or Google Home.

Option 7: Remotely unlock the door via app, if the G2 gateway is paired.

### **Lock the Door**

Option 1: The handle lock is automatically locked after 5 seconds.

Option 2: Use the smart App, and press and hold the big lock icon to lock the door.

Option 3: Use the keys provided to manually lock the door.

Option 4: If auto-lock is not enabled, touch any keys to light up the keypad first, then press and hold the # key to lock the door.

## How to Reset the Lock

Unscrew the interior assembly, press the reset button until you hear “Please input the initialization passcode”, then enter the code 000# to complete the reset.

**Note:** Keep the cable connected and batteries properly installed.

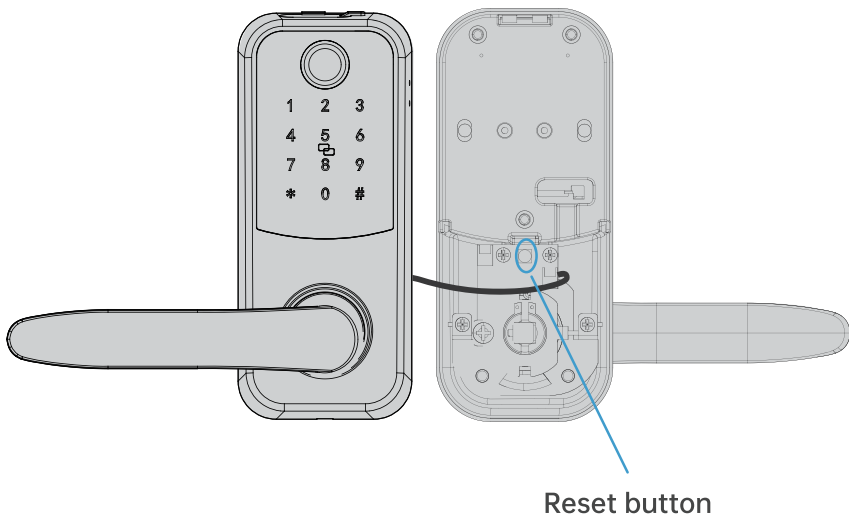

## Enabling G2 Gateway (Sold separately)

To set up the G2 gateway for remote control, please follow these steps:

1. Plug in the G2 gateway and wait for the indicator to start flashing red and blue alternately.
2. Add the gateway to your App and turn on the Remote Unlock function.
3. Once successfully paired, the gateway indicator will keep flashing blue and a small lock icon will appear on the home page.

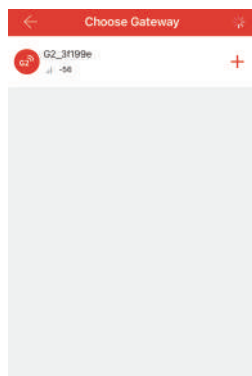
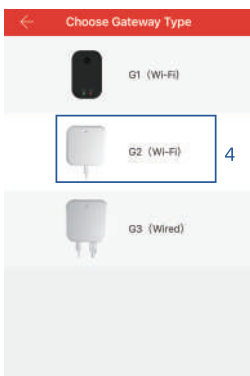
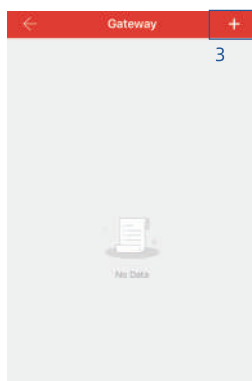
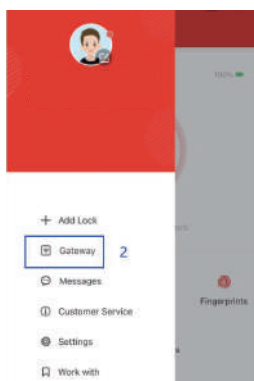
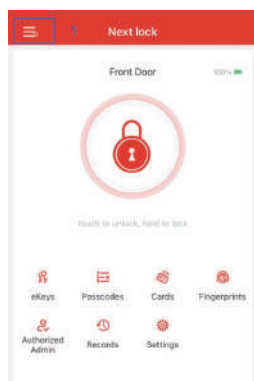

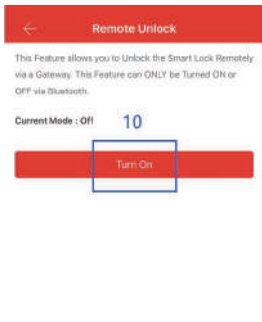
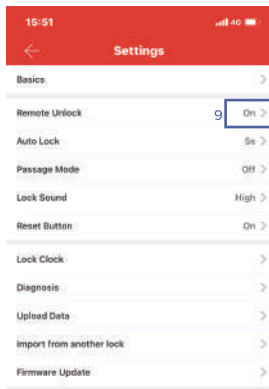
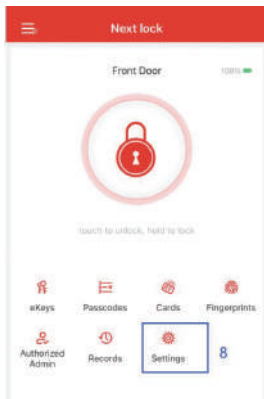
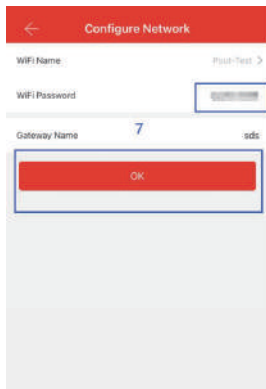

**Remote control**  
**Unlock:** Tap the small lock icon.  
**Lock:** Press and hold the big lock icon.

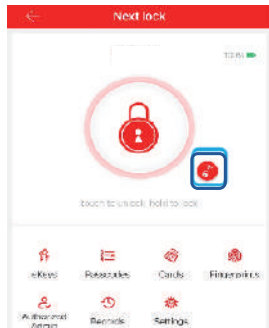

## Notes:

1. Only support 2.4GHz WiFi, our G2 gateway enables you to remotely unlock your door anywhere anytime.
2. To ensure best performance, place the gateway within 5m/16 feet from the smart lock and router.

# Enabling Amazon Alexa

**Preparation:** Pair the G2 gateway with the lock in advance, and enable the “Remote Control” function in the Settings section on the homepage of the Next lock App.

**Step 1:** Tap “Menu” icon in Alexa App

**Step 2:** Select “Skill & Games”

**Step 3:** Search for “Nextlock”

**Step 4:** Tap “Enable to use”

**Step 5:** Log into your Next lock account and then choose “Authorize”

Note: If your account is a phone number, please prefix it with the appropriate country code (eg US: +1 \*\*\*\*\*).

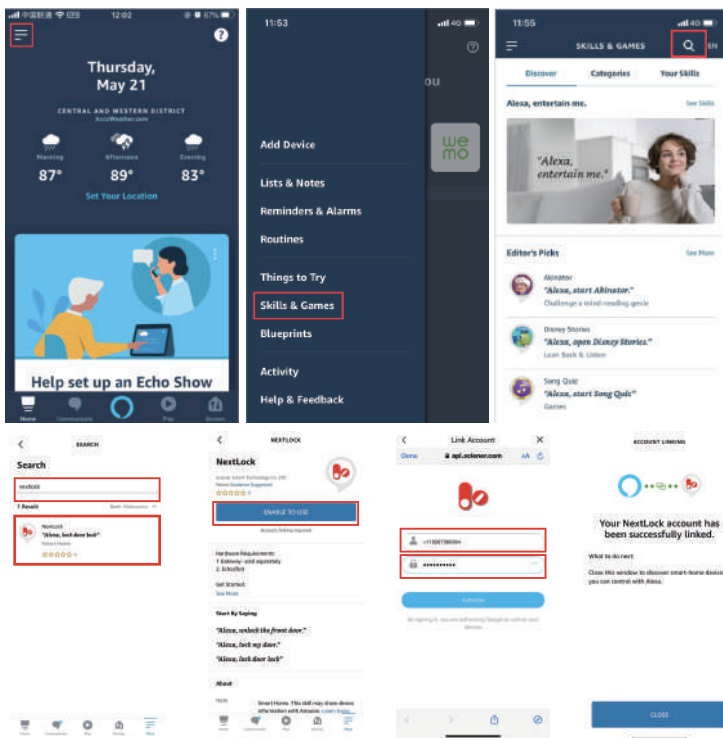

Turn On “Unlock by app” and “Unlock by voice” in Alexa App  
Tap “Locks” → Select your lock → Tap “Settings” icon → Turn on  
“Unlock by App” and “Unlock by voice”

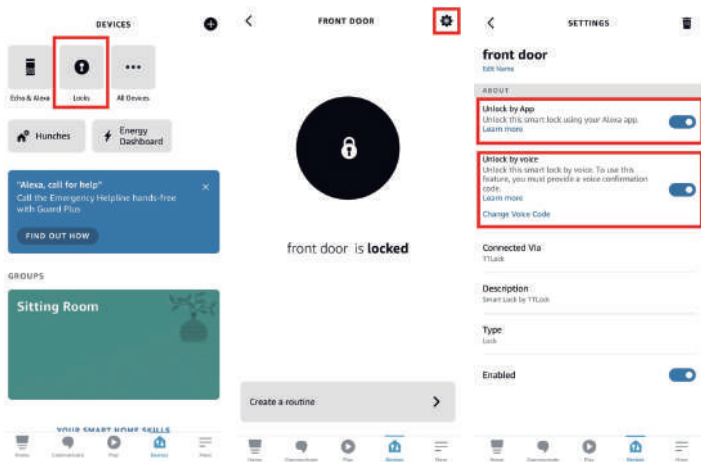

## Enabling Google Home

**Preparation:** Pair the G2 gateway with the lock in advance, and turn on the “Remote Control” function in the Settings section on the homepage of the Next lock App.

**Step 1:** Open the Google Home app and log into your Google Account.

**Step 2:** Tap the Add (+) option in the upper left corner.

**Step 3:** Select “Set up device” and choose “Works with Google”

**Step 4:** Search for “ScienerSmart” and log into your Nextlock Account.

**Step 5:** In the Nextlock App, tap “Menu” in the upper left corner, then select “Work with” → Google Home → Turn on, and set a 4-9 digit security code.

Google will ask you for this security code when you unlock your door using voice commands.

Problems	Solutions
<b>How to change the handle direction?</b>	Refer to the part "Change the handle direction" for details (Page 5).
<b>How to lock or unlock the door?</b>	Refer to the Basic Operations→Lock the Door &Unlock the Door (Page 22 )
<b>How can I share access to the lock with my family and friends?</b>	Send them "eKeys" or use "Authorized Admin" to grant them access. Simply follow the steps outlined in the app
<b>Where can I find my App account?</b>	Go to the App homepage and tap the "menu" icon in the top left corner. Then tap your profile photo to check your account information.
<b>What should I do if I enter wrong passcodes 5 times and the alarm goes off?</b>	Wait for 5 minutes and try again, or use the App or keys provided to open the door.
<b>How to find and change the Admin passcode?</b>	Go to Settings→Basics→Admin Passcode in the App. Tap the code to change it (make sure the Bluetooth is on and your phone is within 5 meters from the lock).
<b>What's the difference between "eKeys" and "Authorized Admins"?</b>	While "eKeys" only allow others to unlock or lock the door via Bluetooth, "Authorized Admin" enable the recipients to further program the lock.
<b>How to enter the passcode on the keypad?</b>	Touch the keypad to light it up, then enter the passcode you've set and press the # key to confirm.

Problems	Solutions
<b>Can the voice be muted?</b>	Stand nearby your lock, open the App and turn on your phone's Bluetooth, tap <b>Settings</b> on the App homepage→ <b>Lock Sound</b> → <b>Turn off Lock Sound</b>
<b>Can one IC card be used on multiple locks?</b>	One IC card can match different door locks, but if the card is lost or stolen, it can pose a security risk.
<b>How to prevent prying eyes?</b>	Simply add extra digits before or after your real passcode and SMONET smart lock will still unlock.

## Customer Service

All SMONET products come with lifetime support. Feel free to contact us if you have any questions.

**Email:** [aftersaleservice@smonet.com](mailto:aftersaleservice@smonet.com)

**Toll free:** 1-888-308-5626

**Mon-Sun:** 12 pm-8 pm, 9 pm-6 am (EDT)

WhatsApp





smonet

[www.smonet.com](http://www.smonet.com)